

NOW AVAILABLE

**TIRE**  **PILOT**  
PLUS™

**SAF** 

# CBX40 AEROBEAM™

THE LIGHTEST AND TOUGHEST TANDEM SLIDER AIR SUSPENSION  
SOLUTION AVAILABLE FOR VAN AND REEFER TRAILERS  
FEATURING OPTIONAL P89 SERIES AIR DISC BRAKES

# THE CBX40 AEROBEAM™ AIR SUSPENSION SLIDER AXLE SYSTEM

The SAF CBX40 AeroBeam™ is the lightest weight slider air suspension available and features a streamlined design for tough performance and reduced weight. The P89™ air disc brake systems are available as options to increase performance and reduce the maintenance costs of your equipment.

**THE INDUSTRY'S LIGHTEST  
WEIGHT SLIDER AIR  
SUSPENSION AXLE SYSTEM.**



**MODEL CAPACITY**  
40,000 LBS.

### Optional Upper Body Rails

Roll formed body rails are manufactured from high strength 80,000 lb. yield steel.

### Slider Sub-Frame

80 ksi steel construction with 16 strategically placed reinforcements improves resistance to damage caused by curb strikes, slider repositioning and drag turns.

### PosiLok™

Minimizes dock walk and suspension squat. Creates a stable and safe loading and unloading operations.

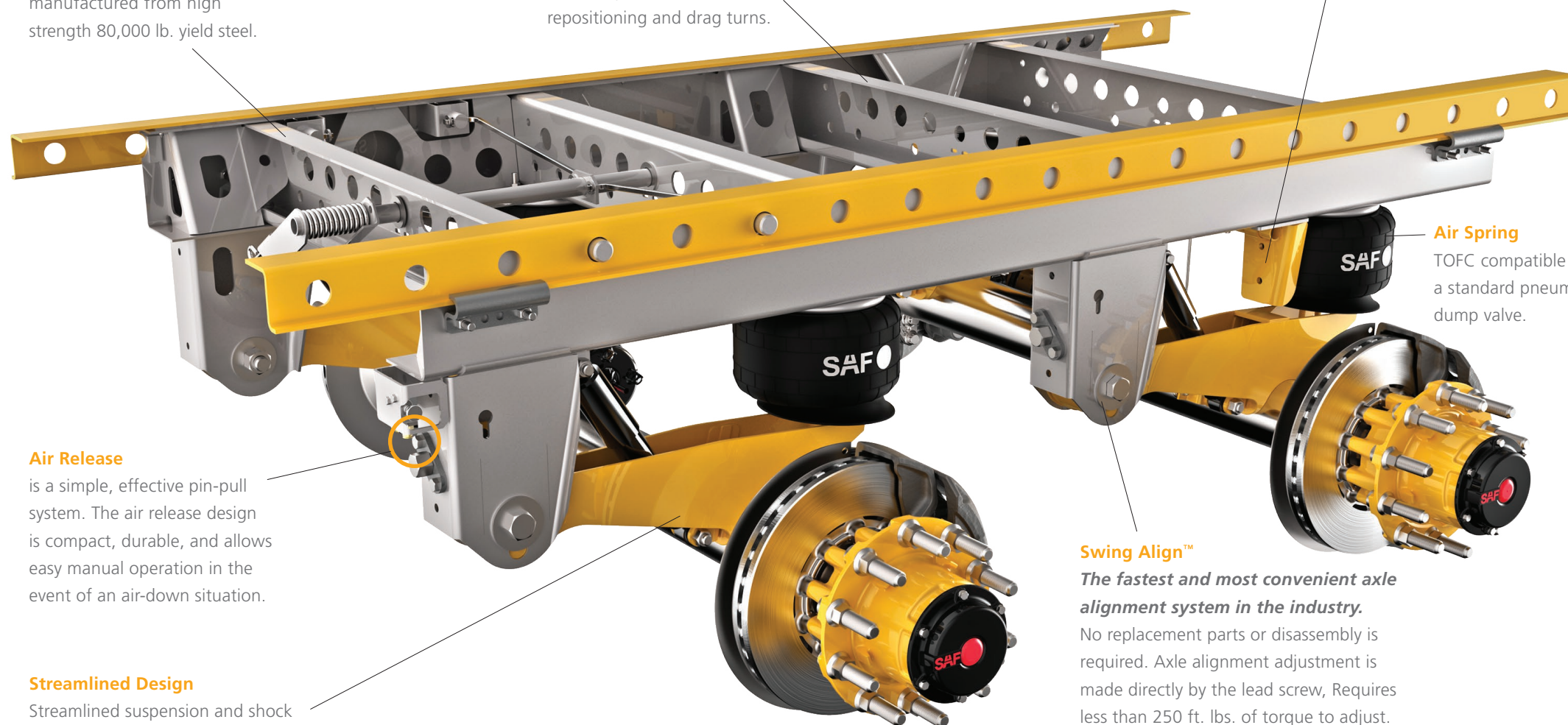

### Air Spring

TOFC compatible with a standard pneumatic dump valve.

### Air Release

is a simple, effective pin-pull system. The air release design is compact, durable, and allows easy manual operation in the event of an air-down situation.

### Streamlined Design

Streamlined suspension and shock absorber design for a compact suspension package with cast steel durability.

### Swing Align™

**The fastest and most convenient axle alignment system in the industry.**

No replacement parts or disassembly is required. Axle alignment adjustment is made directly by the lead screw. Requires less than 250 ft. lbs. of torque to adjust.

OPTIONAL  
**P89 Series**  
™ AIR DISC BRAKES

### Two Model Choices to Meet your Fleet's Specific Needs

The P89 model at a price point that makes sense for fleets of any size. And, the P89 Plus for premium performance. Disc brakes simply provide better performance than drum brakes. They stop shorter for increased safety and reduced maintenance for lower total cost of ownership.

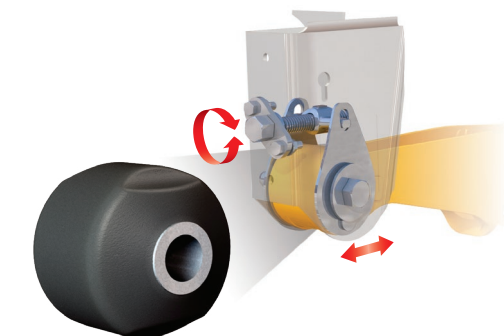

### Multi-functional Pivot Bushing

A robust bushing with its exterior void design limits the twisting movement that could lead to premature bushing and tire wear.

SUPERIOR CORROSION PROTECTION



**BLACK ARMOUR™  
IS STANDARD  
WITH AEROBEAM**





# OPTIONAL P89 SERIES AIR DISC BRAKES

**INDUSTRY LEADING  
AIR DISC BRAKE  
WARRANTY**

See XL-AS11002WC warranty  
statement for complete details.

Proven Design Quality  
with Genuine Value

**All the benefits you expect from the world's leading trailer axle disc brake supplier, at a price point that makes sense for commercial fleets of all sizes.**

**Featuring**

- Heavy-duty venter rotor
- SAF caliper
- Premium matched set bearings
- Parallel or taper spindle
- 5-Year warranty



Premium Performance  
Maintenance Free Design

**Featuring the legendary INTEGRAL® rotor/hub and premium sealed bearings for reduced maintenance.**

**Featuring**

- INTEGRAL® rotor
- Long-life sealed bearings
- Premium brake chambers
- SAF caliper
- Robust parallel spindle
- Premium spindle nuts
- 7-Year warranty

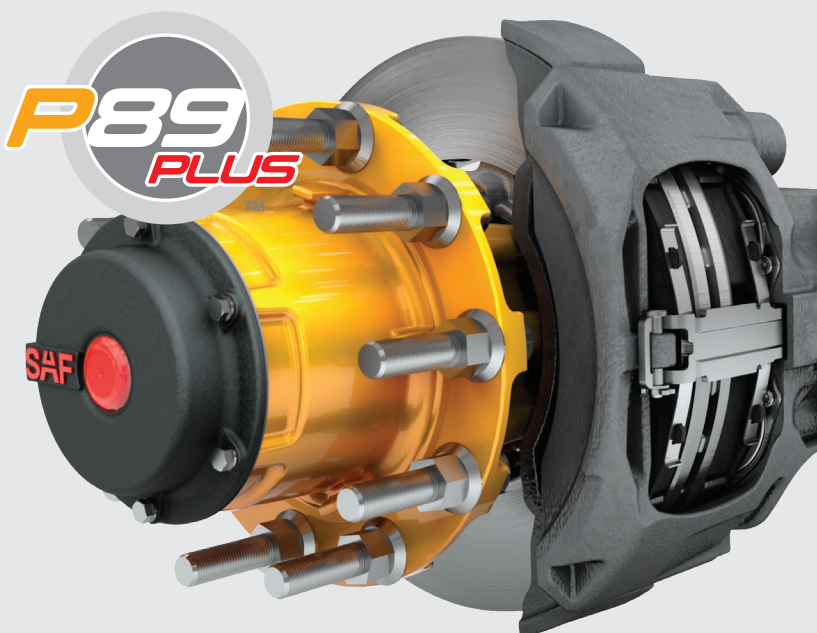

# OPTIONAL ENHANCED TIRE PRESSURE MANAGEMENT SYSTEM



Tire Pilot Plus by PressureGuard  
A Division of SAF-HOLLAND

**IMPROVE PROFITABILITY BY  
ENHANCING TIRE LIFE, FUEL  
EFFICIENCY AND UPTIME**

Optional Tire Pilot Plus™ not only controls pressure through inflation, but also maintains equal pressure across all wheels and features high pressure relief for overinflated tires. The robust design sets it apart from competitive designs with durable components.

- Automatically responds to small leaks caused by road hazards like nails and metal debris.
- System warning light alerts the driver ONLY when there is a need to immediately seek service.
- Diamond knurled hose connections at both hubcaps and tire valve ends allow installation and replacement without a wrench.
- The stainless steel air hose connections are ported through the sides of the hubcap and are protected between the integrated fins.
- High Pressure Relief feature maintains equal and proper pressure for all tires.
- Tire Pilot Plus™ can easily be specified on CBX and ULX Series suspensions, or is available as a simple retrofit on existing trailers.
- Can save over \$750 per year per trailer\*.

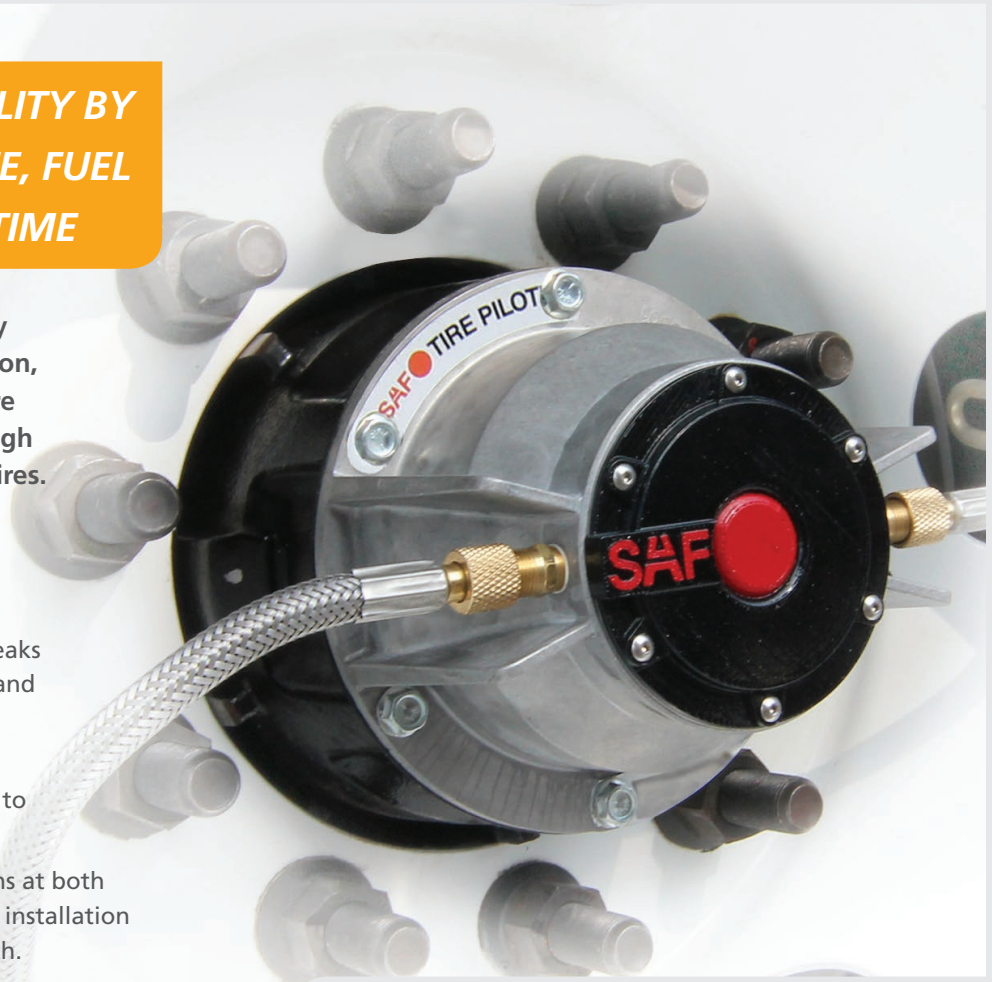

## Proper Air Pressure is Critical to Tire Life

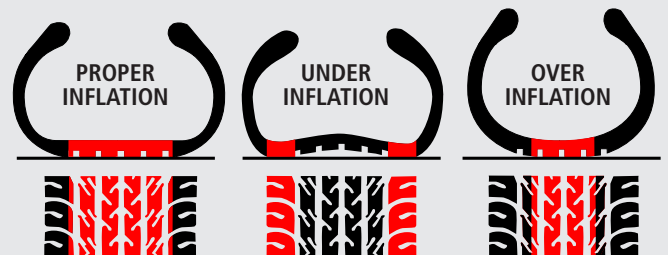

**Full Contact**  
optimizes traction,  
handling and  
maximizes tire life.

**Outside Contact**  
accelerates irregular  
tread wear, increases  
rolling resistance, and  
reduces fuel efficiency  
by up to 2%.

**Center Contact**  
Only reduces tire  
life and traction.  
Tire is susceptible  
to tread damage  
and punctures.

\* TMC RP235 reports the following – Tires underinflated by 10% will wear 9% to 16% faster than properly inflated tires. Underinflated tires add roll resistance that can reduce fuel economy by as much 2%. The average fleet loses \$750 per trailer each year due to improperly inflated tires.

# ADDITIONAL FEATURES

Optional  
Auto-PosiLift™  
for 1% Savings  
in Fuel\*

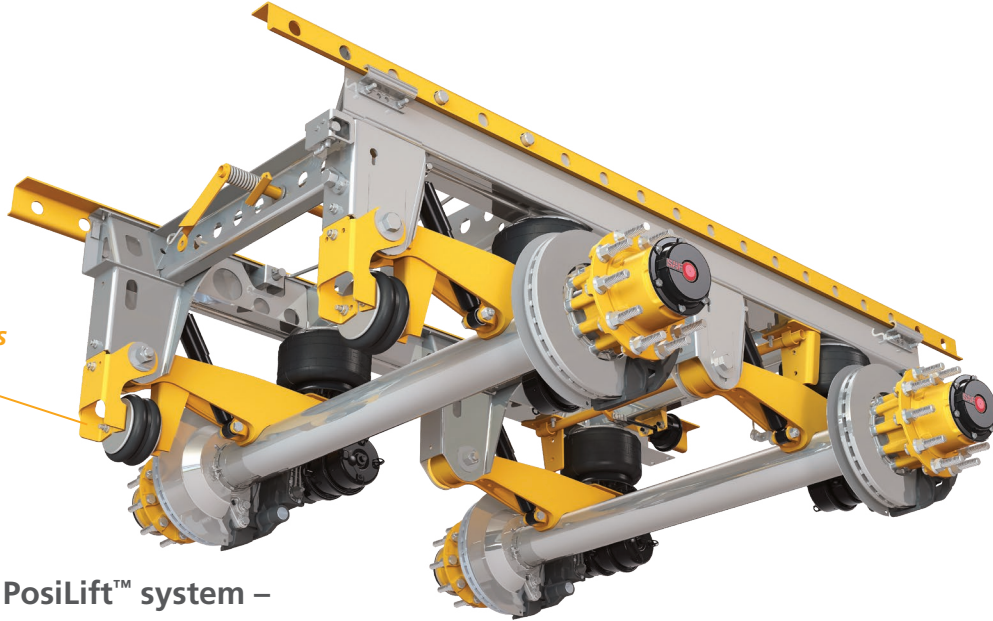

Spec the auto  PosiLift™ system – tested and proven to provide up to a 1% fuel savings!\*

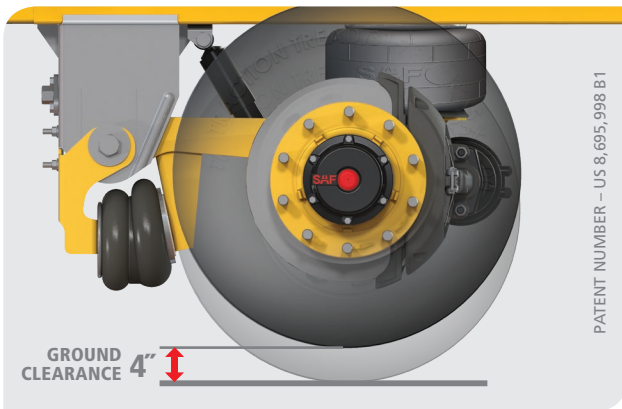

The patented Auto-PosiLift™ feature functions through a programmable ABS with lift axle control to automatically lift the front axle when the system senses that only one axle is necessary to carry the load.

## Significant Bottom Line Benefits

- Up to a 1% fuel mileage savings when axle is lifted
- Increased tire life and reduced tire scrub
- No driver interaction required
- Reduction in toll fees
- Increased suspension component life
- Longer wheel end service intervals

\* Fuel savings calculated per SAE J1526 Type III. Comparison of a less than loaded trailer with and without an Auto-PosiLift™ system.

SAF drum brake axle is standard equipment

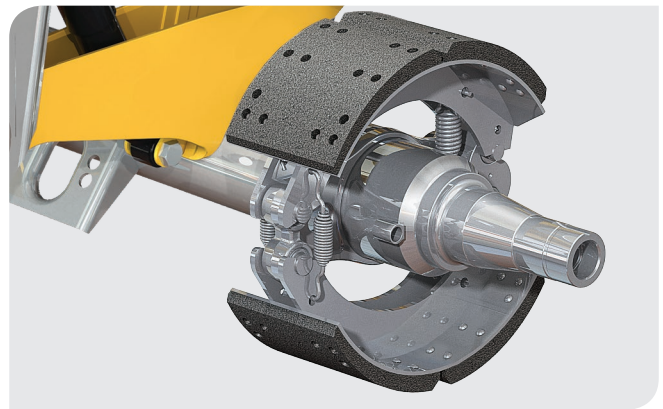

The SAF CBX40 AeroBeam standard configuration features SAF X-Series 5¾" diameter axles with 16½" x 7" extended life brake linings, short cams, and industry standard taper spindles. Optional 16½" x 8⅝" parallel spindles available.

SUSPENSION SYSTEM WEIGHTS**	CBX40
SAF Undressed Drum Brake Axle (16.5" x 7" braked axle only – no slack adjusters or brake actuators)	1,267 lbs.
SAF Dressed Drum Brake Axle (Includes steel hubs/drums, bearings, oil, slack adjusters and brake actuators)	2,037 lbs.***
SAF P89 Series Air Disc Brake Axle	1,967 lbs.

\*\* Weights shown for a base configuration. 48" wide slider, 16" ride height, 77.5" taper spindle axles, air release, no PosiLok™.

\*\*\* Optional lightweight dressed drum brake wheel ends available - 130 lbs. lighter.



# CBX40 AEROBEAM™ SPECIFICATIONS

## CBX40 AEROBEAM

FEATURES	STANDARD	OPTIONS
Ride Heights	16", 16½", 17" & 18"	Upon Request
Slider Width	48"	42" & 54"
Air Release Pin Puller	•	
Patented Qwik Release® Manual Pin Puller		•
Swing Align™	•	
Assembled System	•	
Height Control Valve with Dump	•	
Height Control Valve without Dump		•
Air Springs w/1/4" Ports	•	
PosiLok™ – Anti Dock Walk Device	•	
Auto-PosiLift™		•
Slider Configured to Accommodate 6" Center 1⅜" Body Rails	•	
Slider Configured to Accommodate 4" Center 1⅝" Body Rails		•
Air Tank, Mud Flap & Stinger Brackets		•
Holland Upper Slider Rails		•
Manual Stop Bars		•

## STANDARD DRUM BRAKE AXLE PACKAGE

FEATURES	STANDARD	OPTIONS
Axle Track	77½"	71½", 81½", 83½"*
Spindle	Taper	Parallel
Drum Brake	16½" x 7"	16½" x 8⅝"
Extended Life Linings	SAF Standard 20k	SAF Standard 23k
Tire Inflation Prep: Drilled & Tapped Only		•
Tire Pilot Plus™		•
PSI		•
Cam Enclosures		•
Dust Shields		•
3 Pc. Spindle Nuts		•
Fully Dressed with ABS Sensors		•

## OPTIONAL P89 SERIES AIR DISC BRAKE AXLE PACKAGE

FEATURES	STANDARD	OPTIONS
Axle Track	77½"	71½", 81½", 83½"*
P89 (5 Year System)	•	
P89 Plus (7 Year System)	•	
Spindle – New P89	Parallel	Taper
Spindle – P89 Plus	Parallel	NA
Fully Dressed with ABS Sensors Installed	•	NA
Dust Shields		•
Tire Inflation Prep: Drilled & Tapped Only		•
Tire Pilot Plus™		•
PSI		•

\* Other axle tracks available upon request.

# SAF Holland Group



TRAILER AXLES AND  
SUSPENSION SYSTEMS



COUPLING AND  
LIFTING SYSTEMS



SUSPENSIONS FOR  
TRUCKS AND BUSES



SUSPENSIONS AND  
AXLE SYSTEMS



BUS AIR SUSPENSION  
SYSTEMS



V. ORLANDI  
TOWING  
SYSTEMS



TRAILER AXLES/SUSPENSIONS,  
COUPLING AND LIFTING  
SYSTEMS

[safholland.com](http://safholland.com)

**SAF-HOLLAND, Inc.**

888.396.6501 Fax 800.356.3929

**SAF-HOLLAND Canada Limited**

519.537.3494 Fax 800.565.7753

Western Canada 604.574.7491 Fax 614.574.0244